

SMC Series Cross Connection Cabinet

- High strength glass-fiber polyester (SMC) body
- Pole and pad versions available
- Front access with locking feature
- Provides flexible fiber cable management
- Compatible with all types of PLC splitters
- Unique design minimizes fiber routing congestion
- Pre-connectorized fiber pigtailed installed for rapid deployment



SMC Series Cross Connection Cabinet

Construction

LongXing SMC Series polycarbonate outdoor cabinet is a perfect solution for outdoor fiber connection and distribution applications. Special glass fiber reinforced polycarbonate structure makes this cabinet an ideal solution for cross connect applications.

High strength glass-fiber polyester (SMC) body ensures excellent performance of mechanical durability, anti-erosion, aging resistance and lightweight. The structure is the perfect combination of low weight and high mechanical strength and its functional design gives extra advantages both for installation and cable management.

Units are equipped with wire management and can be ordered pre-configured and tested with pigtails, patch panels with adapters and optical splitters.



Available in these sizes (in mm):

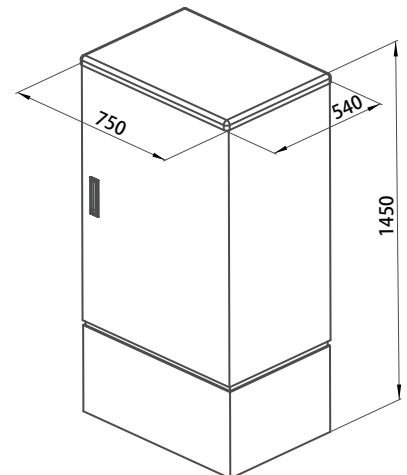
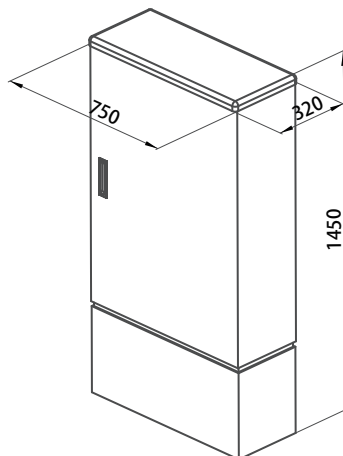
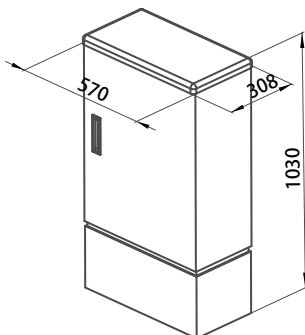

Standard capacity up to 576 cores, in three Models:

GXF-144 (Dimensions: 1030*570*308), GXF-288 (Dimensions: 1450*750*320) and GXF-576 (Dimensions: 1450*750*540).